

PRODUCT FEATURES:

- Hush Feature
- Loose Neutral Monitoring
- Loud 85dB Alarm
- Tamper Proof Design
- Low Battery Signal
- Test Button
- Easy to install
- 5 Year Guarantee
- RF Module Compatible (HSSA/MOD/RF-PRO)

**DESCRIPTION:**

The HSSA/OP/10 is a 230v powered Optical Smoke Alarm with 10 year Rechargeable Lithium Batteries for Backup. The alarm contains a highly accurate sensor, thoroughly tested throughout the manufacturing process for fewer false activations and has been extensively calibrated for optimal fire safety.

TECHNICAL SPECIFICATION:

Grade of Alarm:	D1
Detection Type	Optical Smoke
Power Source:	220-240v AC 50Hz
Backup Power Source:	Lithium Battery with 10-year Life
Approved/Manufactured To:	BS EN 14604:2005
Designed For Installation To:	BS5839-6:2019
Alarm Sound Level:	85dB at 3 metres
Ambient Operating Temp:	0°C to 40°C
Ambient Operating Humidity:	5% to 95% (non-condensing)
Power Consumption (In Alarm):	≤40mA
Power Consumption (Standby):	≤10µA
Min/Max Cable CSA:	0.75mm ² to 1.5mm ²
LED Indicator Function:	Green = Mains Power, Red = Battery/Fault Status
Guarantee:	5 Years
Max Interconnected Units:	20
Max Hardwire Interconnect Distance:	150m
Max RF Connected Units:	20
Max RF Distance:	Open Area 80m, Enclosed Area 30m
Backup Battery Life (No Mains):	30 days
Storage Temperature:	-10 to 50°C
Storage Humidity:	0 to 90% (non-condensing)

*All information is subject to change and should be verified before any critical action.



LINE DRAWINGS:

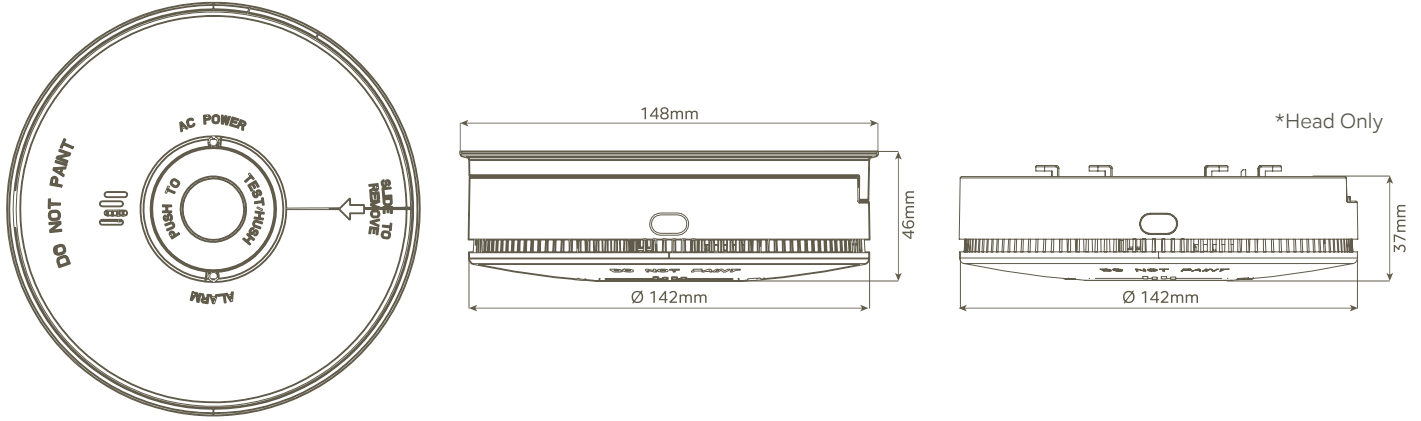

INSTALLATION LOCATIONS:



Hallways



Landings



Living Rooms



Dining Rooms



Bedrooms



Loft Extensions

PRODUCT CONSTRUCTION:

Plastic Housing Material: Fire Retardant ABS

Weight (Unboxed): 260g (Head - 175g)

Cable Entry: Rear Entry and Side (mini-trunking) Knockout



KM 792788
BS EN 14604:2005



**The Kitemark testing has been carried out on a full unit only. If this device is connected to an alternative manufacturer's base, the Kitemark is no longer valid.*

**All information is subject to change and should be verified before any critical action.*

