

# HEAT AND CARBON MONOXIDE ALARM

## PRODUCT FEATURES:

- Hush Feature
- Loose Neutral Monitoring
- Loud 85dB Alarm
- Tamper Proof Design
- Low Battery Signal
- Test Button
- Easy to Install
- 10-year Life Lithium Battery
- RF Module Compatible (HSSA/MOD/RF-PRO)



## DESCRIPTION:

The HSSA/HCO/10 are 230v powered Heat and Carbon Monoxide Alarms with 10-year Rechargeable Lithium Batteries for Backup. The alarm contains a highly accurate sensor, thoroughly tested throughout the manufacturing process for fewer false activations and has been extensively calibrated for optimal fire safety.

## TECHNICAL SPECIFICATION:

Grade of Alarm:	D1
Detection Type	Fixed Heat (60°C) & Electrochemical Carbon Monoxide
Power Source:	220-240v AC 50Hz
Backup Power Source:	Lithium Battery with 10-year Life
Approved/Manufactured To:	BS 5446-2:2003 and BS EN 50291-1:2018
Designed For Installation To:	BS5839-6:2019 and BS EN 50292:2023
CO Alarm Activation Threshold:	50ppm (60-90mins), 100ppm (10-40mins), 300ppm (<3 mins)
Alarm Sound Level:	85dB at 3 metres
Ambient Operating Temp:	0°C to 40°C
Ambient Operating Humidity:	10% to 90%
Power Consumption (In Alarm):	≤40mA
Power Consumption (Standby):	≤10µA
Min/Max Cable CSA:	0.75mm <sup>2</sup> to 1.5mm <sup>2</sup>
LED Indicator Function:	Green = Mains Power, Red = Battery/Fault Status
Guarantee:	5 Years
Max Interconnected Units:	20
Max Hardwire Interconnect Distance:	150m
Max RF Connected Units:	20
Max RF Distance:	Open Area 80m, Enclosed Area 30m
Backup Battery Life (No Mains):	30 days
Storage Temperature:	-10 to 50°C
Storage Humidity:	0 to 90% (non-condensing)

\*All information is subject to change and should be verified before any critical action.



# HEAT AND CARBON MONOXIDE ALARM

## LINE DRAWINGS:

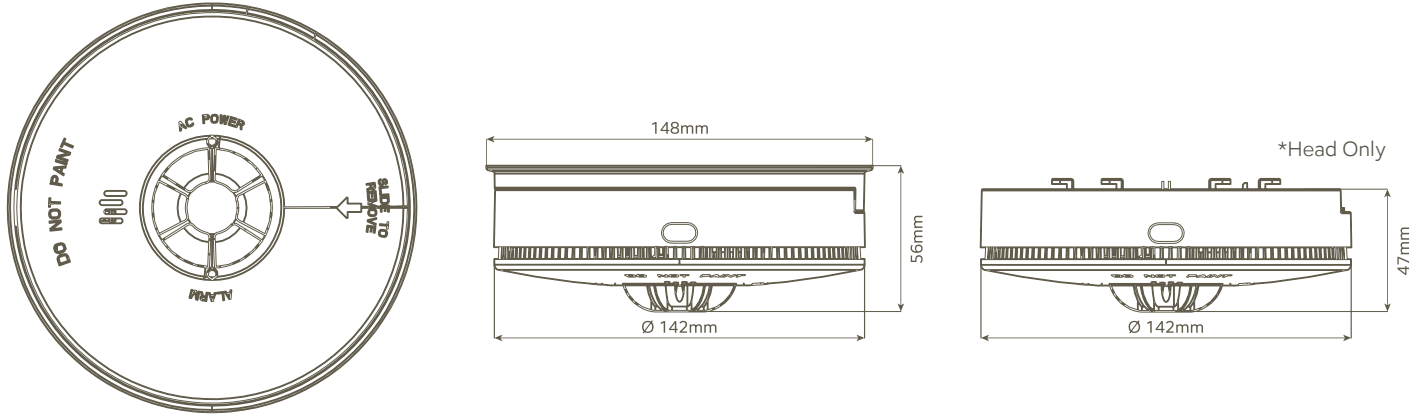

## INSTALLATION LOCATIONS:

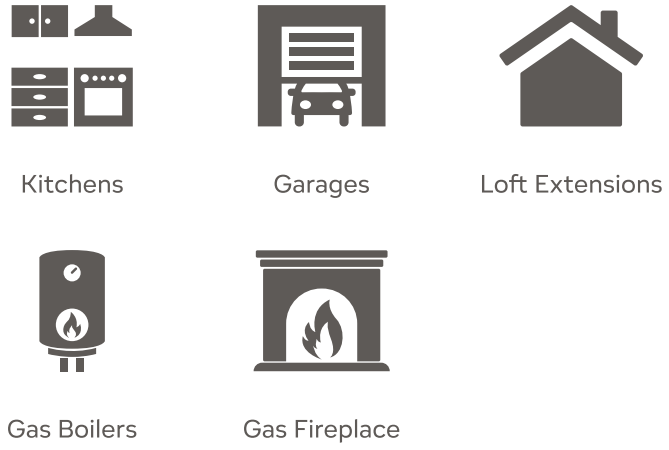

## PRODUCT CONSTRUCTION:

**Plastic Housing Material:** Fire Retardant ABS

**Weight (Unboxed):** 255g (Head - 170g)

**Cable Entry:** Rear Entry and Side (mini-trunking) Knockout



\*The Kitemark testing has been carried out on a full unit only. If this device is connected to an alternative manufacturer's base, the Kitemark is no longer valid.

\*All information is subject to change and should be verified before any critical action.

