

## PRODUCT FEATURES:

- 110V
- 14 Cable with Male & Female Plugs
- 16Amp Rated 3x1.5mm conductors
- Complete with Plastic Hanging Clips
- Hi Visibility Yellow for site safety

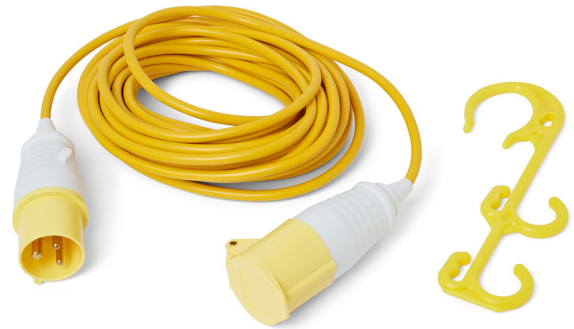

## DESCRIPTION:

14M 110V Extension cable with Male and Female plugs to extend power supplies on temporary and construction sites. 16Amp max rated high visibility cable, supplied with hanging clips to eliminate trip hazards.

## TECHNICAL SPECIFICATION:

<b>Warranty:</b>	2 Year
<b>IP Rating:</b>	IP44
<b>IK Rating:</b>	IK07
<b>Electrical Class:</b>	I
<b>Operating Voltage:</b>	110V AC
<b>Operating Ambient Temperature:</b>	-20°C to 40°C
<b>Materials:</b>	PVC

## PRODUCT CODES:

**HSSL/EXTENSIONCABLE =** Site Light 110V 14M  
3x1.5mm Extension Cable  
& Hanging Clips

## PRODUCT CONSTRUCTION:

**Housing Material:** PVC cable  
**Weight (Unboxed):** 2.05kg  
**Cable Entry:** Male/Female plugs

\*All information is subject to change and should be verified before any critical action.



**LINE DRAWINGS:**

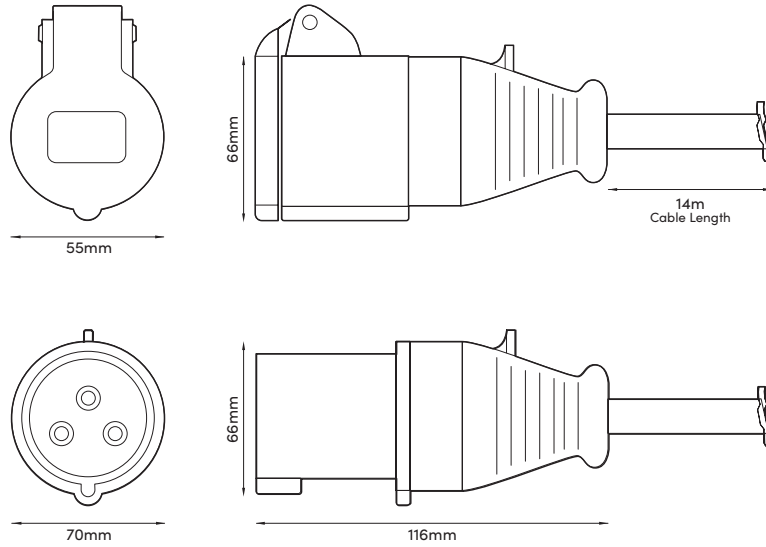

*\*All information is subject to change and should be verified before any critical action.*

