

USER MANUAL



Model: HSSA/HE/10
220-240V AC Operated Heat Alarm
with 10 Year Rechargeable Battery Backup



INTRODUCTION

IMPORTANT: If you are installing this product for use by others, you must leave this manual (or a copy of it) for the end user.

HSSA/HE/10 is a Heat Alarm that can be interconnected to other alarms of the same type. This interconnect feature allows up to 20 Domestic Fire Safety Devices to be connected together over 150 metres maximum, and thus allows all alarms to sound when any one is activated. Alternatively, the alarms can be wirelessly interconnected using a radio frequency module (*HSSA/MOD/RF-PRO Sold Separately*).

SPECIFICATION

Power Supply:	220-240V, 50-60Hz 10 Year 3V Rechargeable Lithium Battery (As backup)
Power Consumption:	≤40 mA (In Alarm)
Detection Type:	Fixed Heat Thermistor (A1)
Activation Temp:	60°C
Temperature Ambient:	0°C to 40°C
Humidity Ambient:	10% to 90% (non-condensing)
Max Wire Interconnection:	20 Units
Max Interconnection Distance:	150m
Alarm Sound Level:	85 Decibels at 3m
Approved by BSI to:	BS 5446-2:2003
Installation Standard:	BS 5839-6:2019 GRADE D1



CLASS II APPARATUS
Detector Classification A1

*The Kitemark testing has been carried out on a full unit only. If this device is connected to an alternative manufacturer's base, the Kitemark is no longer valid.

AVOID THESE LOCATIONS

- Situations where the temperature may fall below 0°C or rise above 40°C for extended periods.
- Humid areas such as **BATHROOMS, SHOWER ROOMS** where the relative humidity may exceed 90% as vapour will cause false alarms.
- Near a **DECORATIVE OBJECT, DOOR, LIGHT FITTING, WINDOW MOULDING** etc., that may prevent hot air from entering the alarm.
- Adjacent to or directly above hot components such as **RADIATORS** or **WALL VENTS** that can affect the direction of air currents.
- In **VERY DUSTY OR DIRTY** environments such as workshops.
- Locate alarm at least 1.5m and route wiring at least 1m away from **FLUORESCENT LIGHT FITTINGS** as electrical 'noise' and/or flickering may affect the alarm. Do not wire into same circuit as fluorescent lights or dimmers.
- Do not locate in **INSECT INFECTED AREAS**, insects and contamination on the alarm sensor can increase its response time.

INSTALLATION - WIRING

- Lift tab to remove terminal cover. See (Figure 9).
- For side entry wiring, remove the knockout where necessary. See (Figure 10).

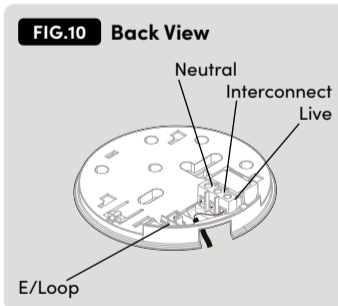
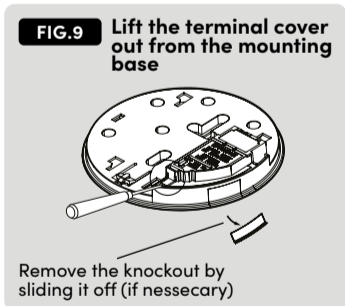

INSTALLER PLEASE NOTE:
WARNING - THIS ALARM IS MAINS POWERED AND REQUIRES WIRING BY A QUALIFIED ELECTRICIAN IN ACCORDANCE WITH THE CURRENT IET WIRING REGULATIONS (BS7671).

WIRING PRECAUTIONS:

- It is important to NOTE that this fire alarm is designed to be interconnected with other Hispec fire safety devices.
- It can be interconnected with up to 39 fire safety devices in total, with a maximum of 20 devices/alarms for wired connections and 20 devices/alarms for wireless connections.
- The alarm has four labeled terminals: Interconnect, Neutral, Earth, and Live. Proper wiring is crucial to ensure correct functionality and to avoid damage that would void the warranty. Please refer to (Figure 11) for guidance on the appropriate wiring.
- When interconnecting fire alarms, ensure that the length of the wire does not exceed 150m, and the spacing between interconnected alarms should not exceed 30m per alarm. The minimum wire cross-section required is 0.75mm². All interconnected fire alarms should be connected to the same final sub-circuit.
- DO NOT USE EARTH AS INTERCONNECT.**
- DO NOT CONNECT LIVE 230v** to the interconnect terminal.
- Connect the IC wire **ONLY** to the IC terminal of other Hispec Fire Safety Devices.
- Fire Alarms should only be connected to individual dwellings as excessive nuisance activations can cause distress.

DIAGRAM

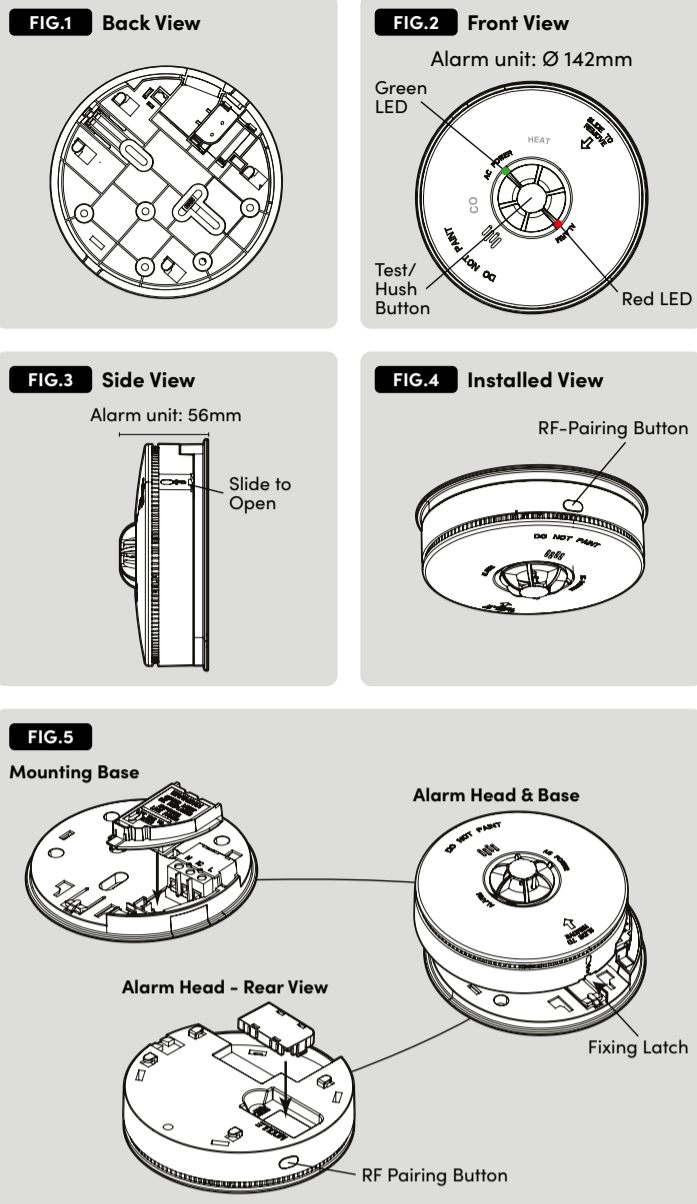

POSITIONING OF THE ALARM

- Heat alarms are intended to be supplementary to smoke alarms and should only be placed in areas where smoke alarms cannot be used.
 - All Fire Alarms should be interconnected to ensure the early warning will be heard, particularly by somebody sleeping. A properly designed early warning fire system ensures the alarm is given before the escape routes become blocked with smoke. This heat alarm gives a fire warning when the temperature at the unit reaches 60°C. It is ideal for kitchens, garages, cellars, boiler rooms, attics and other areas where there are normally high levels of fumes, smoke or dust which preclude the use of smoke alarms due to the risk of false alarms.
 - If your dwelling is on a single storey, for minimum protection, you should fit an alarm in a corridor or hallway between the sleeping and living areas (*incl. Kitchens*). Place it as near to the living areas as possible and ensure the audible alarm can be heard when the bedrooms are occupied. See (Figure 8) for examples.
 - If your dwelling is multi-storey, for minimum protection, one alarm should be fitted at the bottom of the staircase with further alarms fitted on each upstairs landing. This includes basements but excludes crawl spaces and unfinished attics. See (Figure 8) for examples.
- NOTE:** For maximum protection, an alarm should be fitted in every room (*except bathrooms*).

Ceiling Mounting

- As hot smoke rises and spreads out, it is advisable to mount it on a ceiling in a central position. Avoid areas where there is no air circulation. E.g., Corners of rooms and keep away from items which may prevent the free flow of air. Place the unit at least 300 mm from any light fitting or decorative object that might obstruct smoke entering the alarm. Keep at least 300 mm away from walls. See (Figure 6).

Wall Mounting

- Do not mount tightly into the corners. Put the top edge of your fire alarm between 150 and 300mm below the ceiling. Keep at least 300mm from room corners. See (Figure 6).

On a Sloping Ceiling

- In areas with sloping or peaked ceilings, install your alarm in accordance with (Figure 7) because "dead air" at the apex may prevent smoke/heat from reaching the unit.

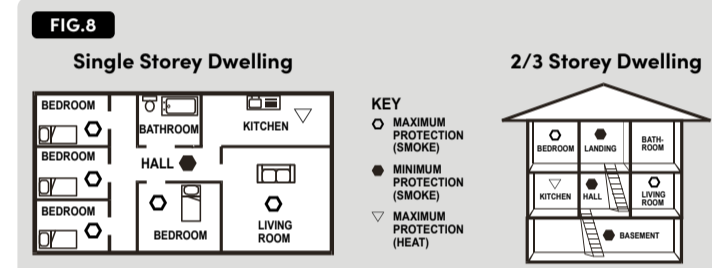
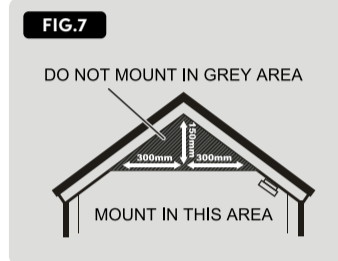
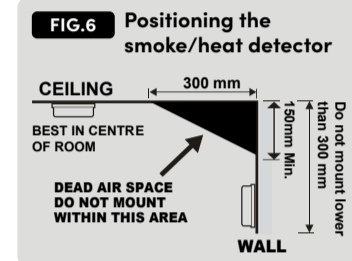

WARNING: LOOSE NEUTRAL CAN RESULT IN DETECTOR FAILURE

If the **RED LED** on the front of the alarm flashes 3 times per second this means there is a loose neutral connection within this alarm circuit. Please ensure all neutral conductors are tightened in their terminals correctly and check for any breaks in the cable run. A strong neutral connection is imperative to avoid an overcurrent within the internal detector's circuitry.

- This product is specifically designed to be connected to 230V, 50Hz AC supply.
- It is important to avoid connecting it to power sources that utilise an inverter, such as a PV solar panel, as this may result in Total Harmonic Distortion (THD) issues.

MOUNTING & TERMINATION

Before installing the fire alarm, it is crucial to thoroughly review the provided instructions. The fire alarm is composed of two parts: the mount base assembly and the alarm unit. It is recommended to keep the alarm unit protected by a plastic dust cover, and separate it until the building commissioning phase. This phase usually involves activities like sanding, preparing for painting, actual painting, and floor laying.

Please follow these steps to mount the fire alarm:

- Choose a suitable location on the ceiling that complies with safety regulations.
 - Separate the mounting base from the alarm head.
 - Strip the Live, Neutral, and Interconnect (if applicable) wires according to the specified strip length shown in (Figure 11).
 - Remove the terminal cover to access the terminals, as depicted in (Figure 9).
 - Connect the wires to the corresponding terminals on the flush mounting base, as shown in (Figure 11). Make sure to securely tighten the screws.
- NOTE:** If you are interconnecting the fire alarms via radiofrequency, do not link out the IC terminals on the alarm mounting base, leave them empty. The interconnect terminal of the fire alarm is only meant for direct hard wire connections with other Hispec Fire Safety Devices.
- Reattach the terminal cover.
 - Securely mount the base to the ceiling using the screws provided.

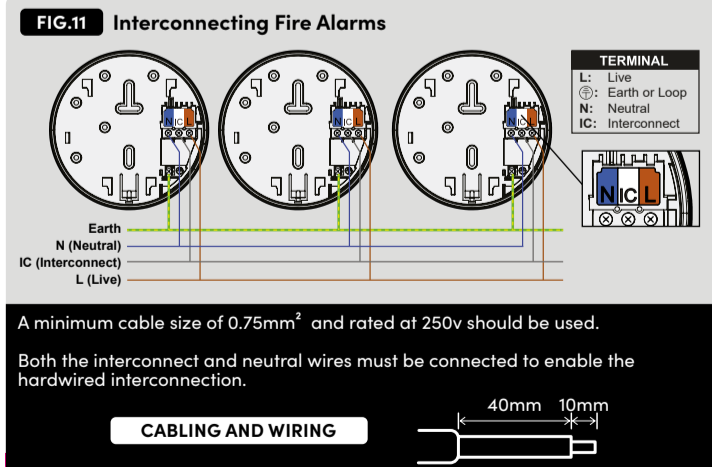

COMMISSIONING

STEPS TO ACTIVATE THE HEAT ALARM:

- Remove the alarm unit from the dust cover.
- Fill out the 'Date of Installation' Label located on the side of the alarm.
- Insert the RF module into the alarm head for wireless interconnection (*optional*) as shown in (Figure 13). SEE SECTION - RF WIRELESS INTERCONNECTION FOR FURTHER DETAILS.
- Align the screwdriver symbol on the head unit with the fixing latch on the mounting base see (Figure 5).
- Slide and firmly push the alarm unit until it clicks into place on the mounting base. The battery activates when sliding into the mounting base. **NOTE:** The battery will activate once the alarm unit is inserted into the mounting base. It is designed to provide a 10-year lifespan during regular operation.
- The alarm is now securely attached to the mounting base, switch the permanent mains supply on to power the alarm. A green LED will be illuminated on the front to indicate mains power, a red flashing LED will illuminate every 40-60 seconds to signal normal operation. If any other sequence of flashing LEDs occur, refer to the **INDICATION AND ACTION** section of this manual.
- Press and **HOLD** the test button for up to 20 seconds, the alarm will sound and trigger any other interconnected units within this period. **NOTE:** After the Test/Hush button has been pressed, wait 10 minutes before any additional testing is conducted to avoid any abnormal responses as the smoke alarm is less sensitive to smoke during this period.

WARNING: In case you encounter frequent false alarms, we recommend relocating the device away from any potential fume sources. If the alarm continues to trigger false alarms even when there is no smoke present, it might require maintenance or cleaning.

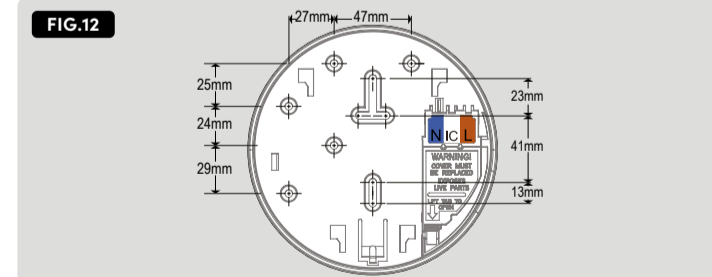

WARNING: LOOSE NEUTRAL CAN RESULT IN DETECTOR FAILURE.

If the **RED LED** on the front of the detector flashes 3 times per second this means there is a loose neutral connection within this alarm circuit. Please ensure all neutral conductors are tightened in their terminals correctly and check for any breaks in the cable run. A strong neutral connection is imperative to avoid an overcurrent within the internal detector's circuitry.

RF WIRELESS INTERCONNECTION

Installing the RF module into the alarm unit:

- Align the RF module parallel to the alarm unit and gently insert it. Avoid applying excessive force to prevent damage. If the RF module doesn't fit immediately, readjust the angle and try again.
- The alarm unit will emit a click sound to indicate successful installation of the RF module.

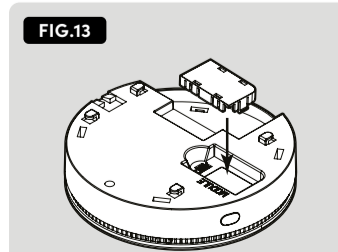

REMOVING THE RF MODULE FROM THE ALARM UNIT:

DUST COVER

The Fire Alarm is enclosed in a plastic dust cover for the following reasons:

- To provide protection for the alarm unit from dust during the building construction phase. Keep the alarm head, while in the dust cover, separate until the building commission phase to prevent dust accumulation and battery degradation. During the commissioning process, it is necessary to remove the dust cover and securely attach the alarm unit to the mounting base.

1. Detach the alarm head from the mounting base as shown in (Figure 13.i).
2. Firmly hold the alarm unit and use an insulated screwdriver to push the head of the RF module, removing it from the alarm unit as shown in (Figure 13.ii).

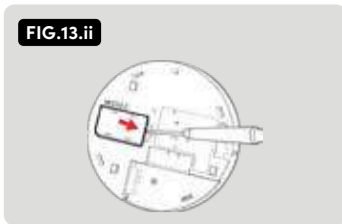

WIRELESS CONNECTING THE ALARM

Wireless pairing the CO, smoke alarm, or heat alarm.

1. On first alarm, press wireless pairing button & hold for 5 seconds until LED lights up.
NOTE: The alarm will stay in pairing mode for 2.5min which will be indicated by a solid RED LED on the front of the alarm.
2. On all additional alarms, press wireless pairing button 2 times.

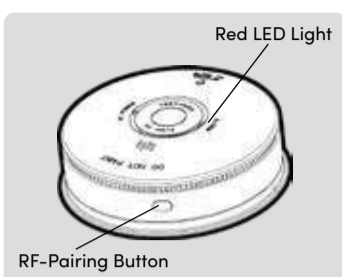

Pairing light will flash RED 5 times. Repeat for each additional alarm.

NOTE: The RF pairing button is only used for wireless interconnection, and the alarms can only be tested when the alarm isn't in pairing mode.

Clear Pairing Memory

Press the RF pairing button 5 times, the red LED on the alarm will flash 10 times.

OPERATION

This alarm has a built-in feature to detect the power source. If the Live (L) connection is present and the alarm is activated, it operates as a 220-240V mains-powered smoke alarm. In this case, the battery acts as a backup and lasts for 10 years from installation.

If mains power is not present and the alarm is activated, it relies solely on battery power. The battery, under normal conditions, lasts for 30 days.

WARNING: SLIDING THE ALARM HEAD ONTO THE MOUNTING BASE WITHOUT MAINS POWER CONNECTED WILL DRAIN THE BATTERY. CONNECT AC MAINS POWER ASAP TO RECHARGE THE BATTERY.

SAFESPEC APP

Download data from this alarm and export reports via the Safespec app. Download Safespec for IOS or Android by scanning the QR code.



1. Open the Safespec app and press "Download Alarm Data".
2. Press "Test/Silence" 4 times, triggering extraction noise.
3. Direct the bottom of the device within 20cm of the alarm until the status report appears.

TESTING

It is recommended that you test your alarm once a week to ensure the alarm is working correctly. Push and hold the test button for approximately 3 seconds (at

it is recommended to seek professional assistance for replacement or servicing.

LIMITATION OF HEAT ALARMS

- Heat alarms are not designed to protect life safety against fire and smoke. In most fires, hazardous levels of toxic gases and smoke can build up before the heat alarm will operate. Heat alarms should only be used to provide an added source of protection.
- Heat alarms cannot provide an alarm if heat does not reach the unit. Therefore, heat alarms may not sense fires starting in chimneys, walls, on roofs, on the other side of a closed door or on a different floor. Home fires develop in different ways and are often unpredictable.
- Standard heat alarms do not effectively alert individuals who have hearing impairments. For those with hearing impairments, it is advised to use specialised devices such as Hispec Strobe Lights and Vibrating Pads to ensure everyone in the building is alerted during a fire emergency.
- By being aware of these limitations, individuals can take proactive measures to optimise the effectiveness of their heat alarms and prioritise their safety by taking appropriate precautions against the risks of fire.

GUARANTEE

WARNING: DO NOT ATTEMPT TO OPEN THE HOUSING.

This alarm is in guarantee under normal use and service for a period of 5 years (including battery) from date of purchase. The company will not be obligated to repair or replace parts which are found to be in need of repair because of misuse, damage or alterations present after the date of purchase. If the alarm is proven to be faulty, within the guarantee period, it must be returned to where it was purchased, carefully packaged, with the fault clearly stated along with proof of purchase. The liability of the company arising from the sale of this alarm shall not in any case exceed the cost of replacement of the alarm and in no case shall the company be liable for consequential loss or damages resulting from the failure of the alarm.

least 20 seconds to trigger other alarms). A loud pulsating alarm should sound and a RED indicator light (LED) will flash at the same time.

NOTE: For multiple interconnected alarms, only the RED indicator light (LED) of the originating unit will flash rapidly. All other units in the interconnect system will sound an alarm but their RED indicator light (LED) will NOT flash. Test each alarm checking that the alarm is triggered on all other alarms installed.

WARNING: NEVER USE AN OPEN FLAME OF ANY TYPE TO TEST YOUR ALARM. WARNING: DO NOT APPLY EXCESSIVE FORCE ON THE "HUSH/TEST" BUTTON THIS MAY DAMAGE THE SMOKE ALARM AND MAY VOID THE WARRANTY.

Featured LED and Alarm Signal

Fire Warning Signal - The fire alarm will sound a loud alarm (85 dB) and the red LED will flash rapidly. This will continue until the air is cleared.

Standby - The red LED flashes once every 40-60 seconds to indicate the heat alarm and battery are functioning correctly.

Memory Function - If one of the alarm indicators (RED LED) is flashing every 4 seconds, it indicates that a heat alarm has previously been activated.

Low Battery - The heat alarm indicates a low battery by flashing the red LED once and emitting a chirp every 40-60 seconds.

GREEN LED

Green LED - The green LED is illuminated when the mains power (220-240V) is on. If the heat alarm is powered only by battery. The Green LED will not be illuminated.

HUSH OR SILENCE FUNCTION

- This Fire Alarm has a built-in Hush or Silence feature incorporated into the Test/Hush button. If cooking or other non-hazardous sources cause the alarm to sound, it can be temporarily silenced by pressing the Test/Hush button for 1 second. The alarm will then enter a dormant period for 10 minutes. After the 10 minute dormant period, the Fire Alarm will resume normal operation.
NOTE: After the Test/Hush button has been pressed, wait 10 minutes before any additional testing is conducted to avoid any abnormal responses as the smoke alarm is less sensitive to smoke during this period.
- This Fire Alarm has a self-diagnosis. If the smoke alarm detects the battery is low and/or an internal fault, it will chirp. This alarm can be temporarily silenced by holding the Test/Hush button for 1 second. The alarm will not chirp for 10 hours but the alarm will continue to function. It is recommended to replace the alarm as soon as possible after this period of time.
NOTE: Silence will not affect the basic fire warning functions of a Fire Alarm. During the silenced period, if the alarm detects fire, it will still emit a fire signal.

FIG.14

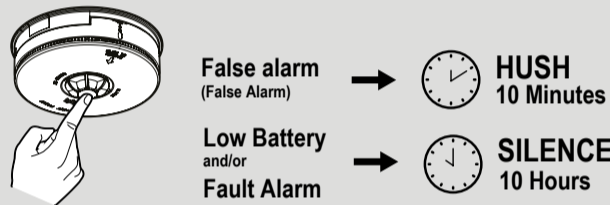

WARNING: IF THERE IS ANY QUESTION AS TO THE CAUSE OF AN ALARM IT SHOULD BE ASSUMED THAT THE ALARM IS DUE TO AN ACTUAL FIRE AND THE DWELLING SHOULD BE EVACUATED IMMEDIATELY.

INDICATION AND ACTION

If you notice any signals from the fire alarm and you're unsure about its state, consult the provided table below for the "LED Indicator" and "sounder" of your heat alarm. This table will assist you in identifying the current status of the alarm and the necessary steps to take.

Should you need additional help, we suggest contacting our technical support for any inquiries. The contact details can be found in this manual.

STATUS	LED INDICATOR	SOUNDER	ACTION REQUIRED
Standby Mode (Powered by Battery only)	Green LED not illuminated. Red LED 1 flash every 40-60 sec.	None	Fire alarm in standby condition, powered by internal sealed battery power. Connect the fire alarm to AC Power to complete installation.
Standby Mode (240V AC mains powered)	Green LED illuminated. Red LED 1 flash every 40-60 sec.	None	Fire alarm in standby condition, powered by 240V AC mains and backup battery. No action required.
Fire Alarm Mode	Red LED flashing rapidly until fire is clear.	Chirping rapidly until heat is clear.	Fire alarm detects fire. See section - "In case of fire".
Test Mode	Red LED flashing rapidly (flash pattern sync with the sounder).	Chirping rapidly (Chirp pattern sync with the Red LED).	Release test button to cease test mode.
Low Battery Warning	Red LED 1 flash every 40-60 sec.	1 short chirp every 40-60 seconds (Chirp pattern sync with the Red LED).	The battery is low. Check Section - "Maintenance, Repairs, and Service" for further details.
Memory Function	Red LED 1 flash every 4 seconds, lasting 72 hours.	None	This indication will last for 72 hours. Then, it will automatically resume to standby mode. No action required.
Unit Fault	Red LED 2 short flashes every 40-60 seconds.	2 short chirps every 40-60 seconds (Chirp pattern sync with the Red LED).	The alarm unit is faulty. Check Section - "Maintenance, Repairs, and Service" for further instruction.
Loose Neutral Contact	Red LED 3 short flashes every second.	None	There is a loose neutral connection within this alarm circuit. Ensure all neutral conductors are tightened in their terminals correctly and check for any breaks in the cable run.

IMPORTANT SAFEGUARDS

Installation of your alarm is only one step in your safety plan. Other important steps should be taken to further improve your safety:

- Install the alarm properly, following this instruction leaflet.
- Test your alarm weekly.
- Do not smoke in bed.
- Keep matches & lighters away from children.
- Store flammable materials in a proper manner and never use them near naked flames or sparks.
- Maintain emergency equipment such as fire extinguishers, escape ladders etc and ensure all occupants know how to use them correctly.
- Plan an escape route/s from your building in advance and ensure all occupants are aware of them. Re-enforce this awareness periodically throughout the year.
See below Planning:
 - Create a floor plan that identifies all doors and windows, as well as at least two escape routes from each room. Note that for second-storey houses, rope or chain ladders may be necessary.
 - Hold a family meeting to discuss and review your escape plan, ensuring that each member understands what to do in case of a fire.
 - Designate a predetermined location outside of your home where all family members can meet in the event of a fire.
 - Ensure that everyone is familiar with the sound of the heat alarm and conduct regular practice drills of leaving the home when it goes off.
 - Conduct fire drills at least every six months, including night-time drills.
 - Practicing your escape plan allows you to test its effectiveness before an actual emergency. It is crucial that every member of the household is aware of the plan, as they may need to act quickly and independently in the event of an emergency.

IN CASE OF FIRE

Developing and practicing a plan of escape is essential for ensuring the safety of your household in the event of a fire. When the Fire Alarm sounds, it is crucial that you follow the steps outlined below:

- Evacuate the building immediately using your pre-determined escape plan. Time is crucial, so do not waste time getting dressed or retrieving valuables.
- While exiting, check the surface of internal doors before opening them. If the door feels hot or smoke is seeping through cracks, do not open it. Instead, use an alternative exit.
- If the door feels cool, gently open it, placing your shoulder against it, and be prepared to swiftly close it if heat or smoke rush in.
- If the air is smoky, stay close to the floor and try to breathe shallowly through a damp cloth if available.
- Once outside, proceed to your designated meeting point and ensure that all family members are present.
- Call the Fire and Rescue Services from a neighbour's home, not from your own.
- Do not re-enter your home until officials confirm that it is safe to do so.
- For additional information on fire safety, please contact your local Fire and Rescue Services.

MAINTENANCE, REPAIRS, AND SERVICE

To ensure your fire alarm is properly maintained, repaired, and serviced, it is crucial to follow the appropriate guidelines. Please review the information provided below:

Maintenance:

- To optimise performance, it is advised to conduct a monthly inspection of your heat alarm. Check for any accumulation of dirt, dust, or insects. You can use a vacuum cleaner or a soft brush to gently remove any debris. Additionally, wiping the alarm with a damp cloth will help deter insects. After cleaning, always test the fire alarm to confirm it is functioning correctly.

Repairs / Servicing:

- If you encounter a defective fire alarm, it is important not to attempt any repairs yourself. The unit does not contain parts that can be serviced by the user. Instead,

CE	UK CA
Heat Alarm Devices: HSSA/HE/10	Heat Alarm Devices: HSSA/HE/10
Hispec Electrical Products Ltd., 104 Lower Baggot Street, Dublin, D02 Y940, Ireland 25 Technical Documentation Held by Manufacturer	Hispec Electrical Products Ltd., Chorley North Business Park, Chorley, PR6 7BX 25 Technical Documentation Held by Manufacturer

HISPEC ELECTRICAL PRODUCTS LTD. SHALL HAVE NO LIABILITY FOR ANY PERSONAL INJURY OR PROPERTY DAMAGE, OR ANY SPECIAL INCIDENTAL, CONTINGENT OR CONSEQUENTIAL DAMAGE OF ANY KIND RESULTING FROM A FIRE. THE EXCLUSIVE REMEDY FOR BREACH OF THE LIMITED WARRANTY CONTAINED HEREIN IS THE REPAIR OR REPLACEMENT OF THE DEFECTIVE PRODUCT AT HISPEC ELECTRICAL PRODUCTS LTD. IN NO CIRCUMSTANCES WITHOUT EXCEPTION, SHALL HISPEC ELECTRICAL PRODUCTS LTD.'S LIABILITY, UNDER ANY OTHER REMEDY PRESCRIBED OR OTHERWISE BY LAW, EXCEED THE PURCHASE PRICE OF THE INDIVIDUAL ALARM. YOUR ALARM IS NOT A SUBSTITUTE FOR PROPERTY, DISABILITY, LIFE OR OTHER INSURANCE OF ANY KIND. APPROPRIATE COVERAGE IS YOUR RESPONSIBILITY. CONSULT YOUR INSURANCE AGENT.

This does not affect your statutory rights. This alarm is only suitable for residential dwellings and is not suitable for commercial or industrial use.

Waste electrical products should not be disposed of with normal household waste. Please recycle where facilities exist. Check with your Local Authority or retailer for recycling advice. New regulations will encourage the recycling of Waste from Electrical and Electronic Equipment (European "WEEE Directive" effective August 2005).



Information regarding substances of very high concern (SVHC) according to the Regulation 1907/2006/EC (REACH)

This product contains Lead element, CAS Number: 7439-92-1

UK: Hispec Electrical Products Ltd, Unit 21, Drumhead Road, Chorley North Business Park, Chorley, PR6 7BX

EU: Hispec Electrical Products Ltd, 104 Lower Baggot Street, Dublin, D02 Y940, Ireland

T: 01257 262 197
E: customerservices@hispec.co.uk
W: www.hispec.co.uk