

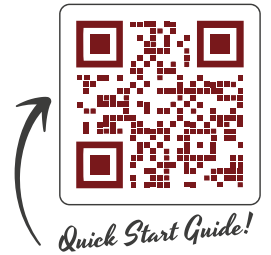

LIGHTING • FIRE & CO DETECTION



COMBO RADIO FREQUENCY FAST FIX MAINS SMOKE & HEAT DETECTOR

WITH 10 YEAR RECHARGEABLE LITHIUM BATTERY

**FAST
FIX REPRO**



FEATURES

- Contains both a smoke chamber & a heat sensor
- Wirelessly interconnect with up to 20 detectors
- 10yr Rechargeable Lithium Battery Backup
- Loud 85dB alarm
- Fast Fix base included
- Insect proof
- Test function and hush feature
- Tamper proof
- Compatible with Hispec Control Unit HSSA/CU/RF10-PRO

TECHNICAL INFORMATION

| | |
|------------------------|--|
| Scheme Rating: | D1 |
| Detection Type: | Smoke & Heat Sensitive |
| Power Source: | 220-240v |
| Battery Backup: | Rechargeable Lithium Battery with 10 year life |
| Alarm Sound Level: | 85dB at 3 metres |
| Temp Rating: | 60°C Fixed Temp (Heat activities) |
| Operating Temp: | 0°C - 40°C |
| Operating Current: | <40mA operation |
| Radio Frequency Range: | Up to 80m in open areas & 30m indoors |
| Ambient Humidity: | 10% - 90% |
| Weight: | 158g |
| Approvals: | BS EN14604:2005/ AC:2008 BS 5446-2:2003 |

Product Code: HSSA/PH/RF10-PRO

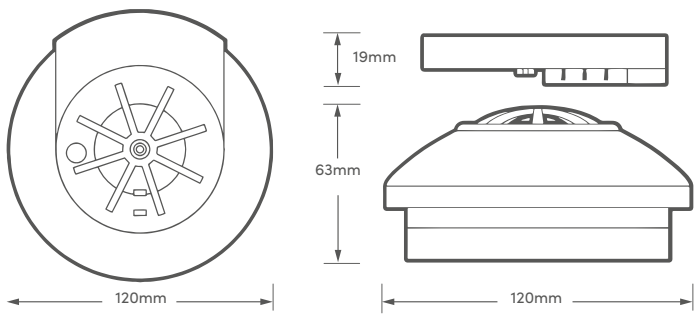

hispec.co.uk

