



RADIO FREQUENCY FAST FIX MAINS HEAT DETECTOR

**FAST
FIX RF**



FEATURES

- Wirelessly interconnect up to 20 detectors
- 9v battery backup included
- Loud 85dB alarm
- Fast Fix base included
- Insect proof
- Test function and hush feature

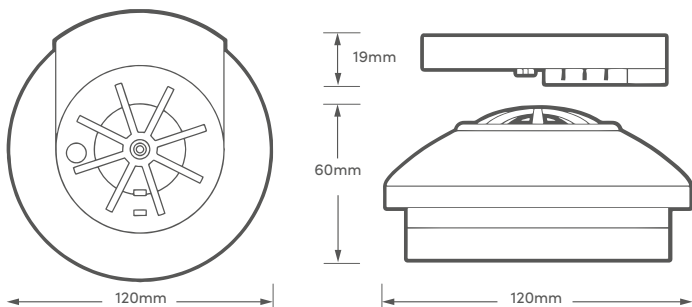

TECHNICAL INFORMATION

Scheme Rating:	D2
Detection Type:	Heat Sensitive
Power Source:	220-240v
Battery Backup:	9v Battery Backup
Alarm Sound Level:	85dB at 3 metres
Operating Temp:	0°C ~ 40°C
Operating Current:	<40mA operation
Radio Frequency Range:	Range of 80m in open areas
Coverage Area:	60m ² max at 2.4m mounting height
Weight:	162g
Approvals:	BS EN5446-2:2003

Product Code: HSSA/HE/RF