



**2CAS**  
OPTICAL SMOKE DETECTOR



**Features**

- Sounder & Beacon Base available
- Low Profile Design
- Anti tamper capability
- Addressable via dip-switches
- Remote LED Output

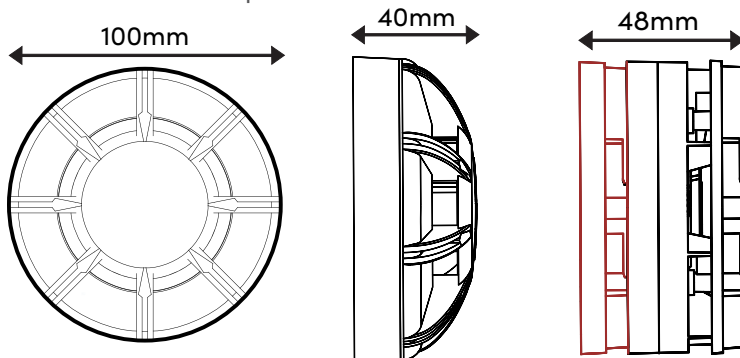

DETECTOR

SOUNDER & FLASHER BASE

**Technical Information**

Detection Type:	Optical
Operating Voltage:	17 - 28v DC
Quiescent current:	500 $\mu$ A
Alarm Current (@24v DC):	5mA
Ambient Op.Temp:	-10°C ~ + 50°C (Min cont. 0°)
Max Humidity:	95% RH Non-condensing
Alarm Condition:	0.09 dB/m - 0.11 dB/m
Coverage:	100m <sup>2</sup>
IP Rating:	IP43
Weight:	164g
Weight W/Sounder Beacon Base:	318g
Approved to:	LPCB
Designed to:	EN54 - 7
<b>Product Code:</b>	<b>HS2CAS/PE &amp; HS2CAS/PE/SB</b>

No.	Tone Description	Pattern	Frequency	Rate
0*	BS Fire (Default tone)	Alternating	800 & 970	1Hz (500ms-500ms)
1	BS Fire	Alternating	800 & 970	2Hz (250ms-250ms)
2	BS Fire	Sweep	800 & 970	1Hz (1 per second)
3	BS Fire	Sweep	800 & 970	7Hz (7 per second)
4	BS Fire	Sweep	800 & 970	50Hz (50 per Second)
5	BS Fire	Alternating	510 & 610	1Hz (500ms-500ms)
6	German fire (DIN 33 404)	Sweep (DIN)	1200 to 500	1Hz
7	French fire (NFS 32-001)	Alternating	554 & 440	100ms-400ms
8*	Dutch fire (NEN 2575)	Slow Whoop	500 to 1200	3.5s sweep, 0.5s silence & Repeat
9	PFEER Toxic Gas	Continuous	970	Steady
10	PFEER alert	Intermittent	970	0.5Hz (1s On/1s Off)
11-15	Reserved			

\*Approved tones

Selection of a reserved sound will cause the sounder to play the default tone, tone 0