



LIGHTING • FIRE & CO DETECTION



COMBO INTERCONNECTABLE FAST FIX MAINS SMOKE & HEAT DETECTOR

WITH 10 YEAR RECHARGEABLE LITHIUM BATTERY



FEATURES

- Contains both a smoke chamber & a heat sensor
- 10 year rechargeable lithium battery back up
- Interconnectable with up to 20 units over 8m max
- Fast Fix base included
- Hush feature
- Loud 85dB alarm
- Test button
- Tamper proof

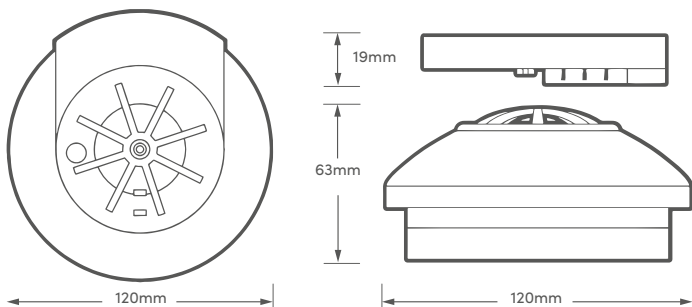

TECHNICAL INFORMATION

Scheme Rating:	D1
Detection Type:	Smoke & Heat Sensitive
Power Source:	220-240v
Battery Backup:	Rechargeable Lithium Battery with 10 year life
Alarm Sound Level:	85dB at 3 metres
Temp Rating:	60°C Fixed Temp (Heat activities)
Operating Temp:	0°C - 40°C
Operating Current:	<40mA operation
Ambient Humidity:	10% - 90%
Weight:	158g
Approvals:	BS EN14604:2005 BS 5446-2:2003

Product Code: HSSA/PH/FF10



hispec.co.uk

