



MAINS INTERCONNECTABLE FAST FIX MAINS HEAT & CO DETECTOR

WITH 10 YEAR RECHARGEABLE LITHIUM BATTERY

FEATURES

- Contains both a heat sensor & a Carbon Monoxide sensor
- Interconnect up to 20 wired detectors
- 10yr Rechargeable Lithium Battery Backup
- Loud 85dB alarm
- Fast Fix base included
- Insect proof
- Test function and hush feature
- Tamper proof

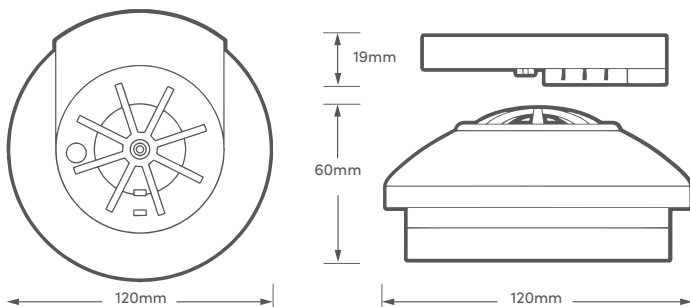

**FAST
FIX**



TECHNICAL INFORMATION

Scheme Rating:	D1
Detection Type:	Heat & CO Sensitive
Heat Sensor:	Thermistor Class A1 detection – Alarm is triggered at 60°C
Carbon Monoxide Sensor:	Electrochemical
Power Source:	220–240v
Battery Backup:	Rechargeable Lithium Battery with 10 year life
Alarm Sound Level:	86dB at 3 metres
Operating Temp:	0°C ~ 40°C
Carbon Monoxide Level (time to alarm):	50ppm (60–90 mins) 100ppm (10–40 mins) 300ppm (<3 mins)
Weight:	158g
Approvals:	BS EN50291-1:2018 BS 5446-2:2003

Product Code: HSSA/HCO/FF10