



LIGHTING • FIRE & CO DETECTION



INTERCONNECTABLE FAST FIX MAINS CARBON MONOXIDE DETECTOR

WITH 10 YEAR RECHARGEABLE LITHIUM BATTERY



FEATURES

- Interconnect up to 20 wired detectors over 80m max
- 10yr Rechargeable Lithium Battery Backup
- Loud 85dB alarm
- Fast Fix base included
- Insect proof
- Test function and hush feature
- Tamper proof

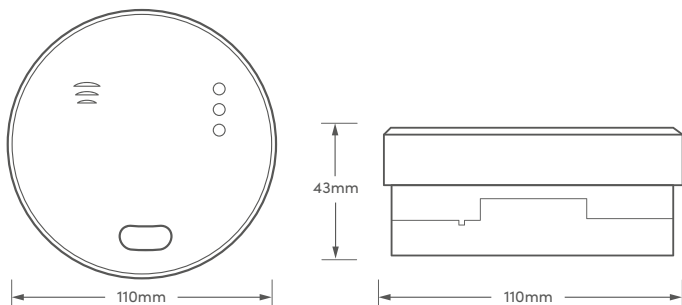

TECHNICAL INFORMATION

Detection Type:	Electrochemical
Power Source:	220-240v AC 50Hz
Battery Backup:	Rechargeable Lithium Battery with 10 year life
Operation Current:	<60mA operation (mains)
Carbon Monoxide Level (time to alarm):	50ppm (60-90 mins) 100ppm (10-40 mins) 300ppm (<3 mins)
Alarm Sound Level:	95dB at 3 metres
Operating Temp:	0°C - 40°C
Ambient Humidity:	15% to 90% relative humidity
Approvals:	EN50291-1:2010 +A1:2012

Product Code: HSSA/CO/FF10



hispec.co.uk

